

SMART WEIGHING SOLUTIONS

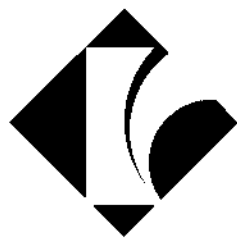

rinstrum

R300 Series
(R310, R320 and R321)
Digital Indicator
Quick Start Manual
For use with Software Versions 1.1 and above

R300-602-150

Copyright

All Rights Reserved. No part of this document may be copied, reproduced, republished, uploaded, posted, transmitted, distributed, stored in or introduced into a retrieval system in any form, or by any means (electronic, mechanical, photocopying, recording or otherwise) whatsoever without prior written permission of Rinstrum Pty Ltd.

Disclaimer

Rinstrum Pty Ltd reserves the right to make changes to the products contained in this manual in order to improve design, performance or reliability.

The information in this manual is believed to be accurate in all respects at the time of publication, but is subject to change without notice. Rinstrum Pty Ltd assumes no responsibility for any errors or omissions and disclaims responsibility for any consequences resulting from the use of the information provided herein.

SPECIAL NOTE

Trade Use of the Rinstrum R300 Series

This manual may occasionally make reference to Trade Use settings of the **R300 Series**.

Some individual settings may not be legal for trade use. Please check regulations with the appropriate Weights and Measures Authority.

“Everything should be made as simple as possible, but not simpler.”

- Albert Einstein -

Table of Contents

1. INTRODUCTION	4
1.1. Approvals	4
1.2. Manuals	4
2. SHIPPING CONTENTS	4
3. SPECIFICATIONS	5
4. WARNINGS	6
4.1. General	6
4.2. Configuration Issues	6
5. INSTALLATION	6
5.1. Electrical Safety	7
5.2. R310/R320 Panel Mount Template	7
5.3. Special Function Key (R320 Only)	7
5.4. rin-LINK	8
6. CONNECTIONS	9
6.1. Cable Connections	9
6.2. DC Power (DC PWR + , DC PWR –)	9
6.3. Load Cell Connection	9
6.4. Auxiliary Connections (R320 only)	11
6.5. Connecting Shields	15
6.6. Regulatory Sealing Requirements	16
7. INSTRUMENT SETUP	18
7.1. Calibration Counter	18
7.2. rin-LINK	18
7.3. Access Full Setup	19
7.4. Access Safe Setup	19
7.5. Exit Full or Safe Setup	19
7.6. Settings	19
8. ERROR MESSAGES	26
8.1. Weighing Errors	26
8.2. Setup and Calibration Errors	27
8.3. Diagnostic Errors	28

1. Introduction

This manual contains information on the installation, calibration and setup of the **R310**, **R320** and **R321**. Any reference to the **R320** also includes the **R321**. Where all instruments are being described they will be referred to as the **R300 Series**.

1.1. Approvals

- NSC approval (4000 divisions at 0.8 μ V/division).
- NMI approval (4000 divisions at 0.8 μ V/division).
- C-tick approved and CE approved.

1.2. Manuals

For more information on the **R300 Series** refer to the **R300 Series Reference Manual**, **R300 Series Operator Manual** and **R300 Series Communications Manual** (available free of charge from www.rinstrum.com).

2. Shipping Contents

The following table identifies the items shipped with indicators. Please check that your packing box contains the specified items.

R310 or R320	R321
<ul style="list-style-type: none"> • R310 Indicator or R320 Indicator • R300 Series Operator Manual • R300 Series Quick Start Manual • R300 Trade Label (plastic) • Panel Mount Template • For R320: R300 Function Key Overlay Stickers 	<ul style="list-style-type: none"> • R321 Indicator • R300 Series Operator Manual • R300 Series Quick Start Manual • R300 Trade Label (plastic) • R300 Function Key Overlay Stickers • R300 Trade Label (metal foil) • M16 Cable Gland Sealing Plug
Other Items (Optional)	
<ul style="list-style-type: none"> • rin-LINK Cable • Power Supply • For R310/R320: Desk Mount with Battery Compartment • For R310/R320: U Bracket 	

3. Specifications

Performance		
Resolution	Up to 30,000 divisions, minimum of 0.25 μ V/division, 20 updates/second (Trade 4000 divisions at 0.8 μ V/division)	
Zero Cancellation	\pm 2.0mV/V	
Span Adjustment	0.1mV/V to 3.0mV/V full scale	
Stability/Drift	Zero: < 0.1 μ V/ $^{\circ}$ C (+ 8ppm of deadload max) Span < 8 ppm/ $^{\circ}$ C, Linearity < 20ppm, Noise < 0.2 μ Vp-p	
Excitation	5 volts for up to 4 x 350 or 8 x 700 ohm load cells (4-wire or 6-wire plus shield) Maximum total load cell resistance: 1,000 ohms	
A/D Type	24bit Sigma Delta with 8,388,608 internal counts	
A/D Conversion Rate	20Hz with FIR filtering > 80dB	
Operating Environment	Temperature: -10 to +50 $^{\circ}$ C ambient Humidity: <90% non-condensing Storage: -20 to +50 $^{\circ}$ C ambient R310 and R320: IP55 when panel mounted, R321: IP65	
Case Materials	R310 and R320: ABS, Silicon Rubber, Nylon, Acrylic (no halogen used)	
Packing Weights	Basic Indicator - R310 and R320: 0.34kg, R321: 2.4kg	
Digital		
Display	LED Backlit LCD with six 20mm high digits with units and annunciators	
Setup and Calibration	Full digital with visual prompting in plain messages	
Digital Filter	Sliding window average from 0.1 to 4.0 seconds	
Zero Range	Adjustable from \pm 2% to \pm 20% of full capacity	
Power Input		
Standard Power Input	12 to 24VDC (2.5 VA max) - ON/OFF key with memory feature	
Variants	AC	AC Plug pack: 110/240VAC 50/60Hz in 12VDC 0.5A out
	Battery	4 x AA batteries (Alkaline or rechargeable NiMH, NiCad, etc.)
Features		
rin-LINK Data Coupling	Infra-red Connector for optional rin-LINK PC cable (to RS-232 PC port)	
R320 Extra Features	Five point linearity correction	
	RS-232 automatic transmit, network or printer outputs. Transmission rate: 2400, 4800 or 9600 baud	
	Assignable function key: Unit switching, counting, manual hold, peak hold, live weight and totalising	
	2 isolated transistor drive outputs (300mA total at 50VDC)	
	Battery backed clock calendar (Battery life 10 years minimum)	
R321 Features	Equivalent to an R320 with IP65 stainless steel housing.	

4. Warnings

4.1. General

- Indicator not to be subject to shock, excessive vibration or extremes of temperature (before or after installation).
- Inputs are protected against electrical interference, but excessive levels of electro-magnetic radiation and RFI may affect the accuracy and stability.
- For full EMC or for RFI immunity, termination of cable shields and correct earthing of the instrument is essential.
- Indicator and load cell cable are sensitive to excessive electrical noise. Install well away from any power or switching circuits.

4.2. Configuration Issues

- Configuration and calibration can be performed from the front panel, using digital setup. When Full Setup is used, all menu items are accessible and care must be taken to ensure no accidental changes are made to calibration and trade settings.
- Enter a passcode to prevent unauthorised or accidental tampering. If the passcode is lost, the manufacturer should be contacted for further advice.

5. Installation

The following steps are required to set up the **R300 Series** indicators.

- Inspect indicator to ensure good condition.
- Use connection diagrams to wire up load cell, power and auxiliary cables as required.
- Use the drill hole template provided for hole locations.
- Connect Power to indicator and press **<POWER>** key to turn the instrument On.
- Refer to the Instrument Setup section page 18 for information on configuring and calibrating the instrument.
- To turn instrument Off press and hold **<POWER>** key for three seconds (until display blanks).

5.1. Electrical Safety

- For your protection all mains electrical hardware must be rated for environmental conditions of use.
- Pluggable equipment must be installed near an easily accessible power socket outlet.
- To avoid the possibility of electric shock or damage to the instrument, always switch off or isolate the instrument from the power supply before maintenance is carried out.

5.2. R310/R320 Panel Mount Template

Use the **R310/R320** panel mount template for drill hole locations. The template indicates positions for the two 4mm mounting screws through the panel. Also displayed on the template is the position of the rectangular hole that should be cut to allow for the connection of cables. The drilling template supplied with the indicator allows for front or rear machining of the panel.

5.3. Special Function Key (R320 Only)

- The Special Function Key on the **R320** ships as a blank key.
- If any of the special functions are to be used on the indicator it is important that the matching function key overlay sticker (supplied) is applied to the keypad.
- Ensure keypad is clean and dry before affixing sticker.

5.4. rin-LINK

The optional rin-LINK cable can be used to transfer setup and calibration information from a PC (eg. to be stored for later use and/or transferred to other instruments). It can also be used to download software upgrades to the instrument from a PC.



- Attach the rin-LINK cable to the PC using the DB9 connector.
- Attach the rin-LINK head to the left side of the instrument display using the permanent magnet located within the head of the rin-LINK.

WARNING: The rin-LINK head contains a strong magnet and care should be taken with its proximity to electronic media (eg. credit cards, floppy disks, etc.) and/or other electronic instrumentation.

5.4.1. rin-LINK Activation

A long press of the <**GROSS/NET**> key will toggle the rin-LINK infrared communications On/Off.

When the rin-LINK has been (enabled) the following will occur:

- The instrument briefly displays the prompt **rin-L**.
- The editing annunciators (ie. GRP, ITM, etc.) will flash for up to five minutes while the instrument searches for activity. During this period, the **R320** also disables the RS-232 communications.
- **Activity Located:** If the instrument is **successful** in locating activity, the editing annunciators will continue to flash during the entire period of communications.
- **No Activity Located:** If the instrument **fails** to locate activity, the rin-LINK will be disabled and the editing annunciators will stop flashing. The **R320** will also revert back to the normal RS-232 communications (ie. the SERIAL:TYPE setting will be re-activated).

6. Connections

6.1. Cable Connections

- All cable connections are made to the rear of the instrument using screwless terminals.
- Wires must be stripped of insulation by at least 10mm.
- To install, depress the orange lever beside the terminal required and push wire into the hole. Release the lever and pull gently on the wire to ensure it is securely trapped in the terminal.

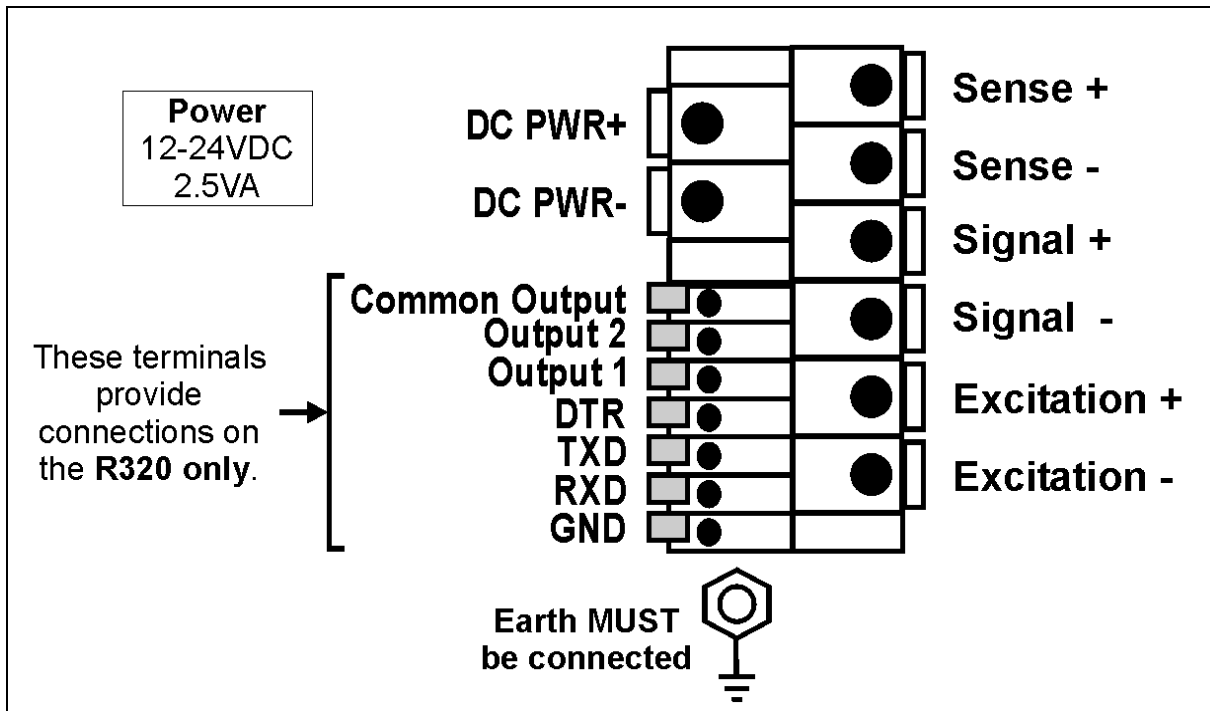

6.2. DC Power (DC PWR + , DC PWR –)

- The DC supply need not be regulated, provided that it is free of excessive electrical noise and sudden transients.
- The instrument can be operated from a high quality plug-pack as long as there is sufficient capacity to drive both it and the load cells.

6.3. Load Cell Connection

The **R300 Series** units may be connected for either 4-wire or 6-wire operation. For more information, refer to **BUILD:CABLE** setting page 20.

6.3.1. 4-Wire Connection

The minimum connectivity requirements are the connection of four wires (ie. Excitation + and – along with Signal + and –).

The BUILD:CABLE option must be set to **4** to allow for 4-wire connection.

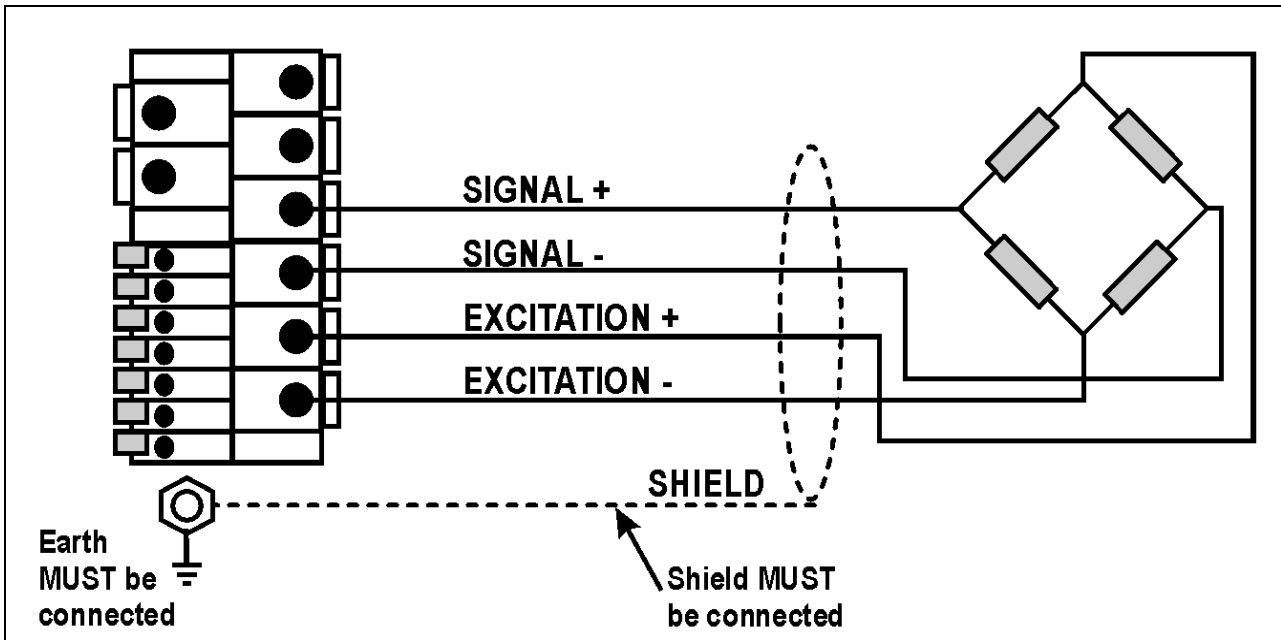

6.3.2. 6-Wire Connection

The excitation and signal lines are connected the same as for a 4-wire installation.

The BUILD:CABLE option must be set to **6** (the default) to allow for 6-wire connection.

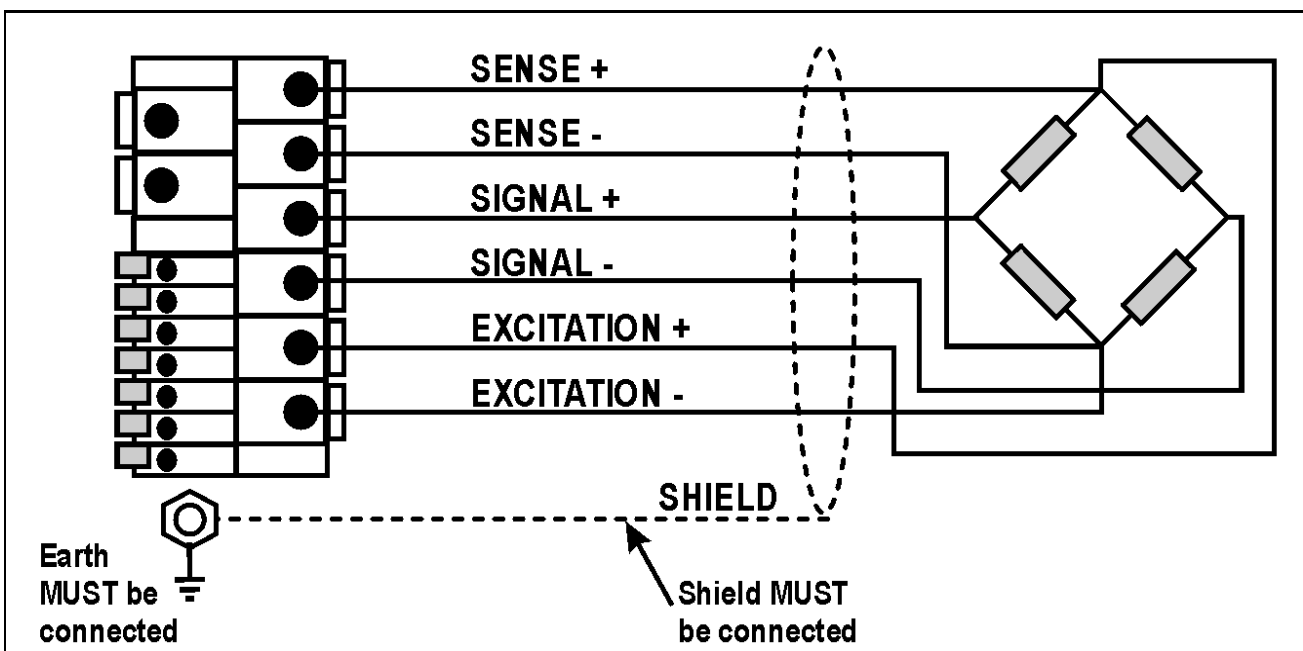

6.4. Auxiliary Connections (R320 only)

This section provides diagrams to illustrate the R320 terminal connections.

6.4.1. Direct Personal Computer Link (RXD, TXD, GND)

RS-232 - R320 to PC using COM Port (DB9)

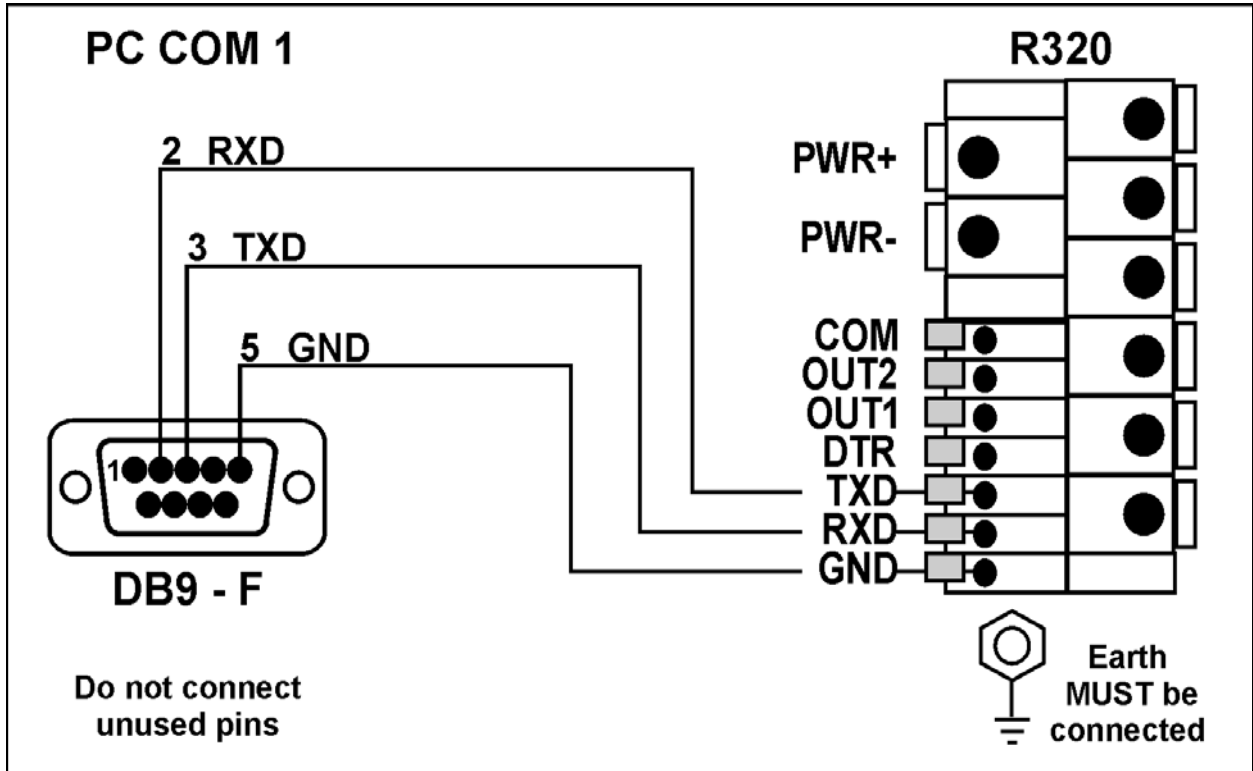

RS-232 - R320 to PC using COM Port (DB25)

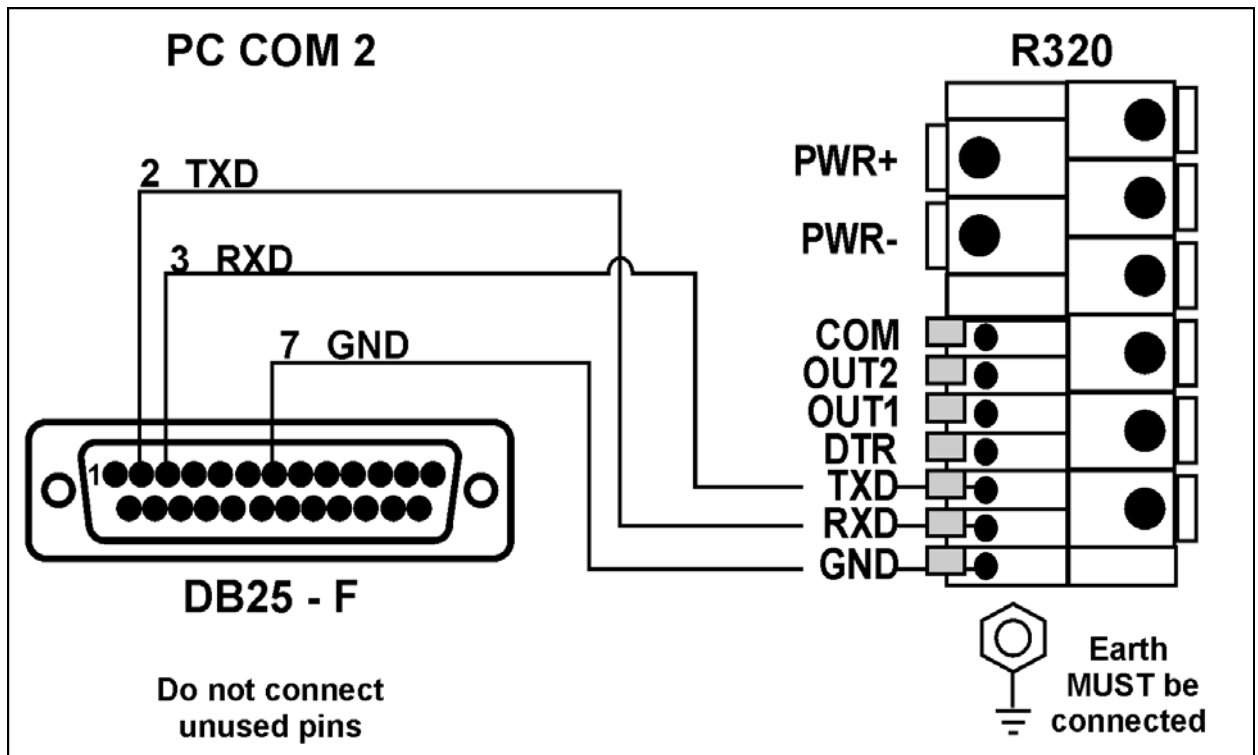

6.4.2. Printer Connections (RXD/TXD, GND and DTR)

RS-232 - R320 to Printer (DB25)

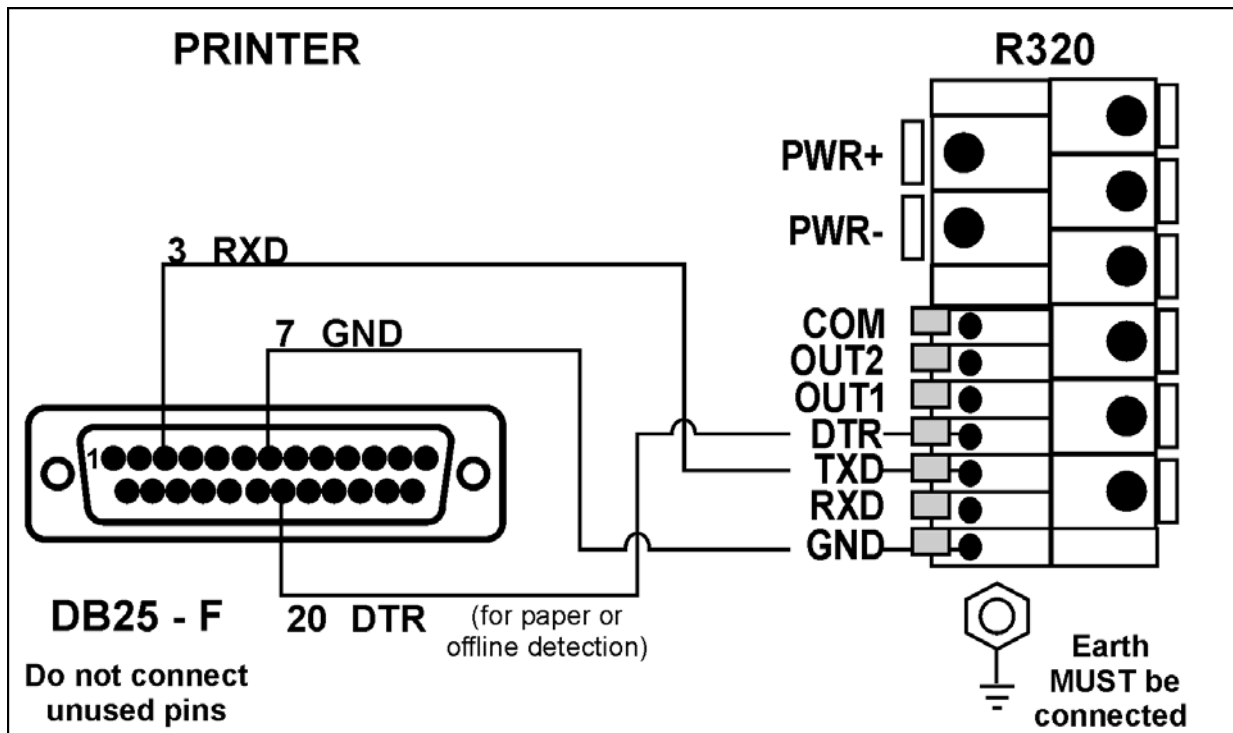

6.4.3. Remote Display (TXD, GND)

- Connect TXD to RXD and GND to GND on the remote display.

6.4.4. Remote Input

- The indicator requires a voltage free contact between TXD and RXD to enable the remote input (ie. SPEC:REM.FN). **Note:** The remote input will not function when in setup or when using the rin-LINK.

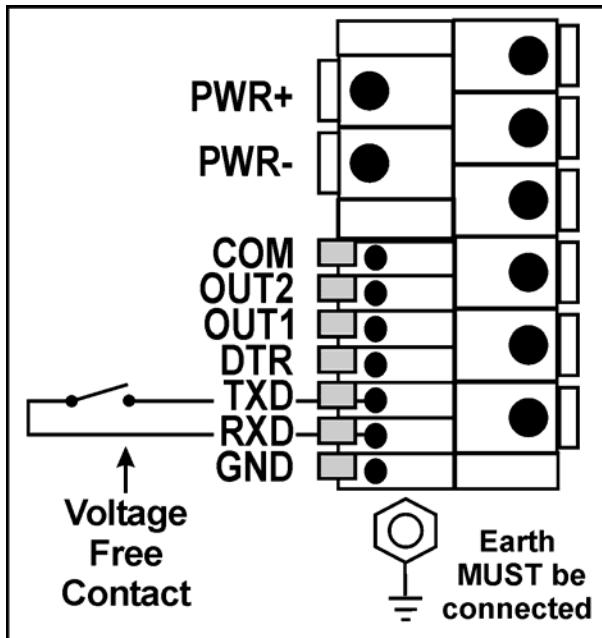

WARNING

The remote input is a voltage free contact (eg. button, mechanical relay). Connection of any active circuitry may damage the instrument.

6.4.5. Outputs

- Output drivers for the **R320** are isolated open emitter transistor drives that are capable of driving up to a total of 300mA.
- This configuration allows for the direct connection of the **R320** outputs to most types of PLC.
- The voltage applied to the COM terminal appears on the output lines (ie. OUT1 and OUT2) when the outputs are active (eg. to connect to a PLC connect +24V to the common terminal). The outputs can then be connected directly to PLC inputs so when the outputs are active the PLC will see a 24V signal.
- To drive external loads (eg. relays), connect the relay coil positive supply to the output common and the output line directly to one side of the relay coil.
- Connect the other end of the relay coil to the negative supply. It is recommended that fly-back diodes or transient suppressors be fitted across relay coils to limit switching noise.

R320 Outputs to Drive Relay

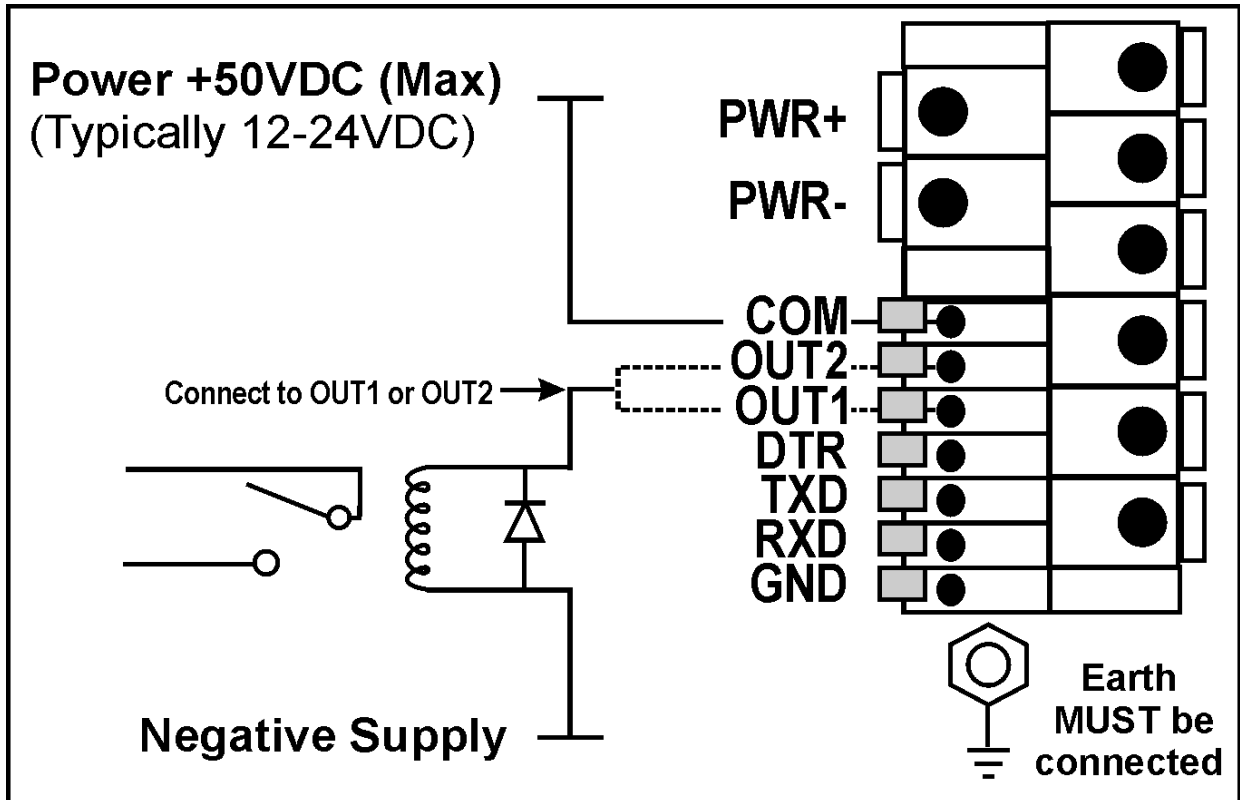

R320 Outputs to Drive PLC

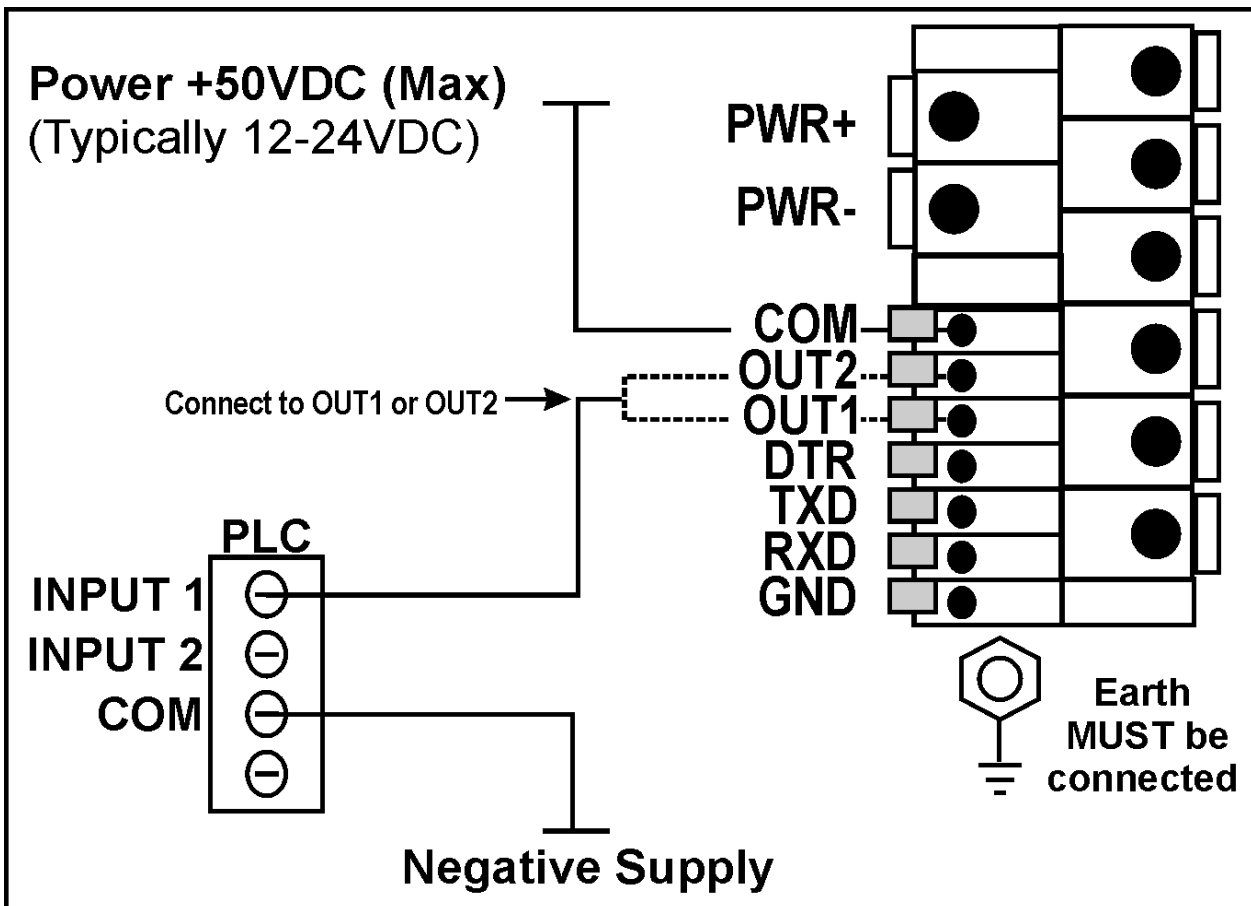

6.5. Connecting Shields

To obtain full EMC or for RFI immunity, cable shields MUST be connected to the earth lug on the rear of the instrument.

This figure shows the connecting cables restrained using cable ties fastened around the cable strain relief anchors.

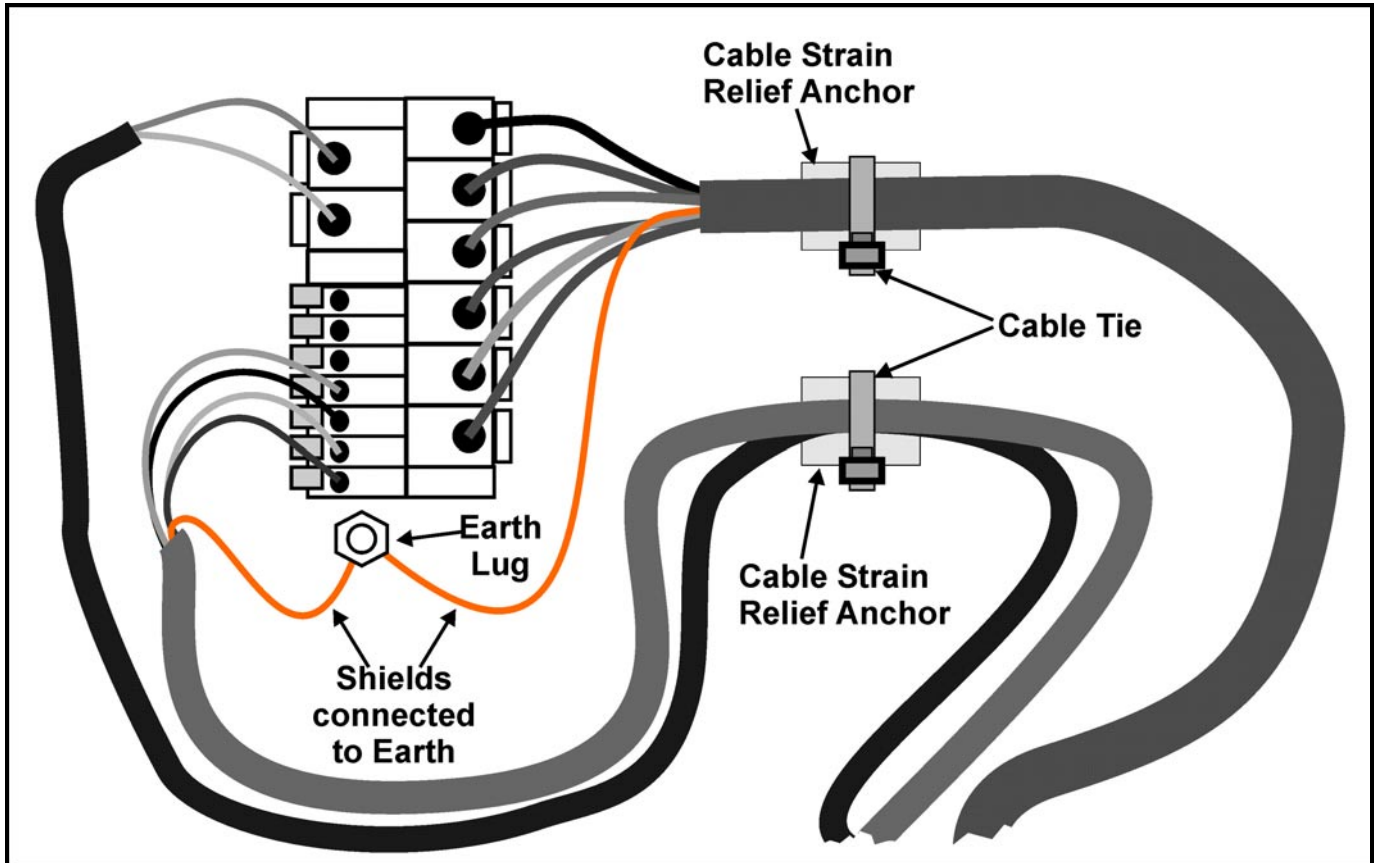

6.5.1. Cable Shield Connection and Earthing

- Care should be taken when connecting shields to maximise EMC or RFI immunity and minimise earth loops and cross-talk (interference) between instruments.
- For full EMC or for RFI immunity, termination of the cable shields at the earth lug is very important. The earth lug of the instrument must be separately connected to ground potential via a reliable link.
- The instrument should only be connected to earth via a single reliable link to avoid earth loops.
- Where each instrument is separately earthed, interconnecting cable shields should be connected at one end only.
- **Caution:** Some load cells connect the cable shield directly to the load cell (and therefore the scale base). Connection of the load cell cable shield in this situation may be site specific.

6.6. Regulatory Sealing Requirements

To comply with regulatory sealing requirements for each instrument, (ie. to ensure instruments are not accidentally or deliberately tampered with), it is important that proper sealing procedures be adhered to.

6.6.1. R310 and R320 Sealing (R320 shown)

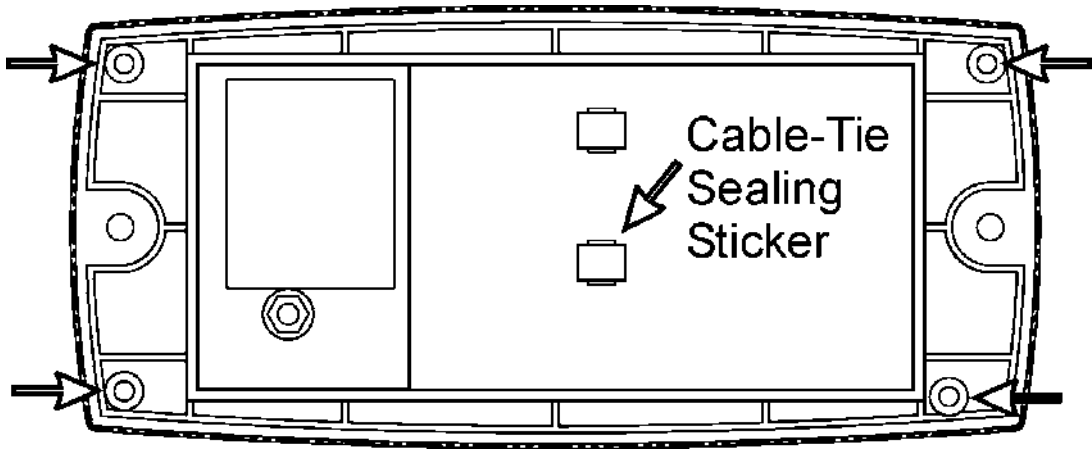

For the **R310** and **R320**, affix sealing stickers to the rear of the instrument, over one or more screws in the locations indicated.

Also affix a sealing sticker over the load cell cable where the cable-tie strain relief is attached, as indicated.

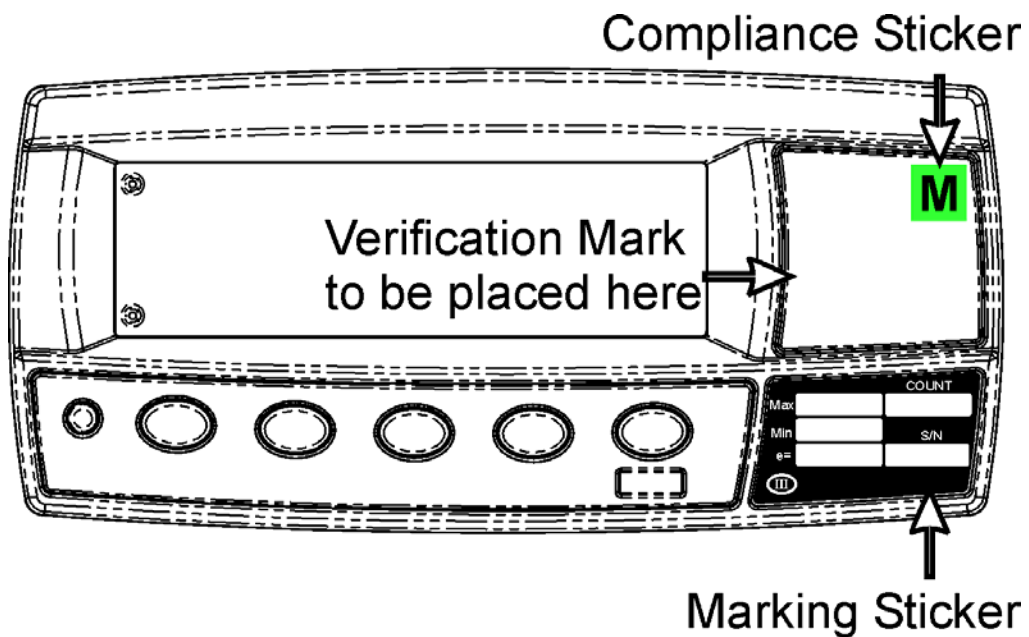

Affix stickers in the locations indicated.

6.6.2. R321 Sealing

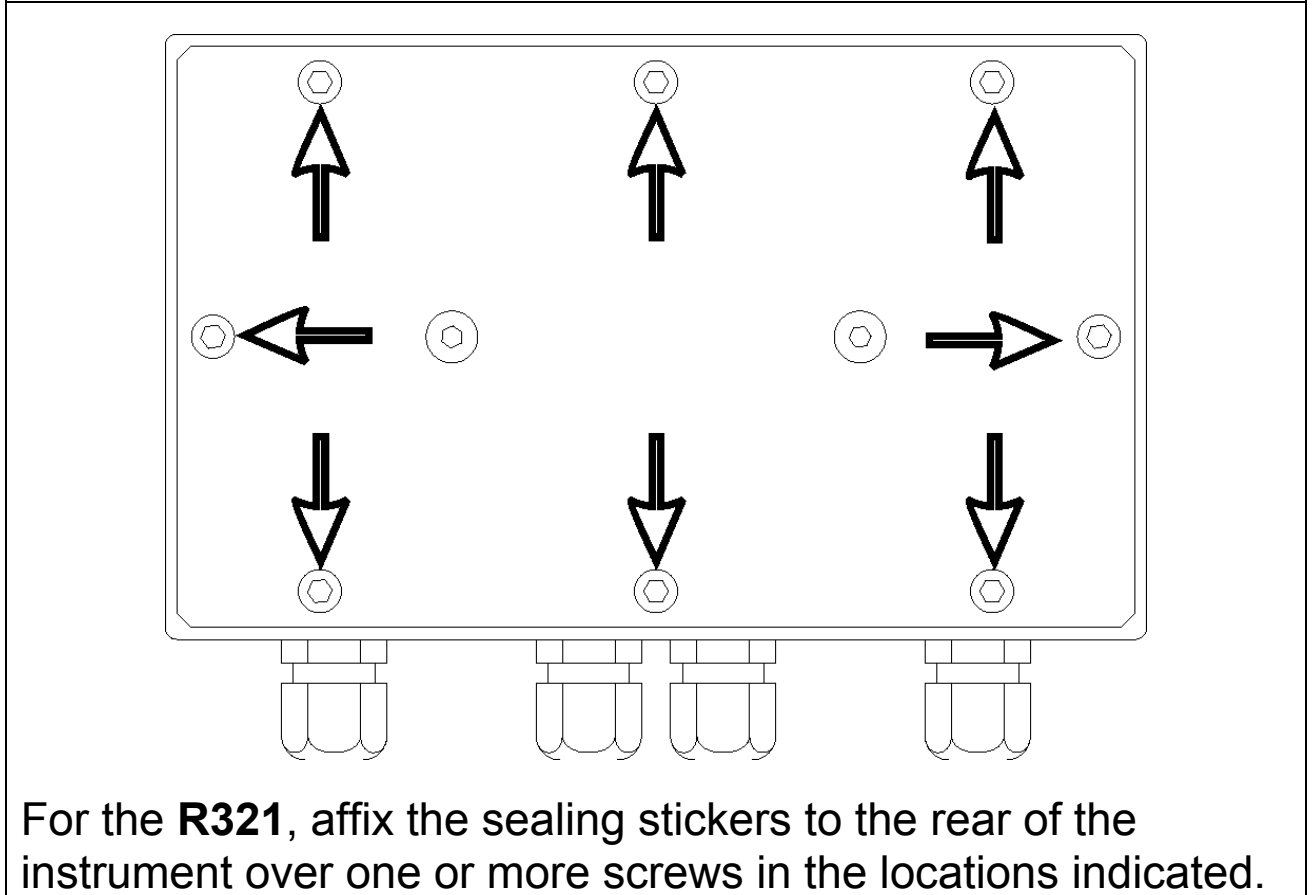
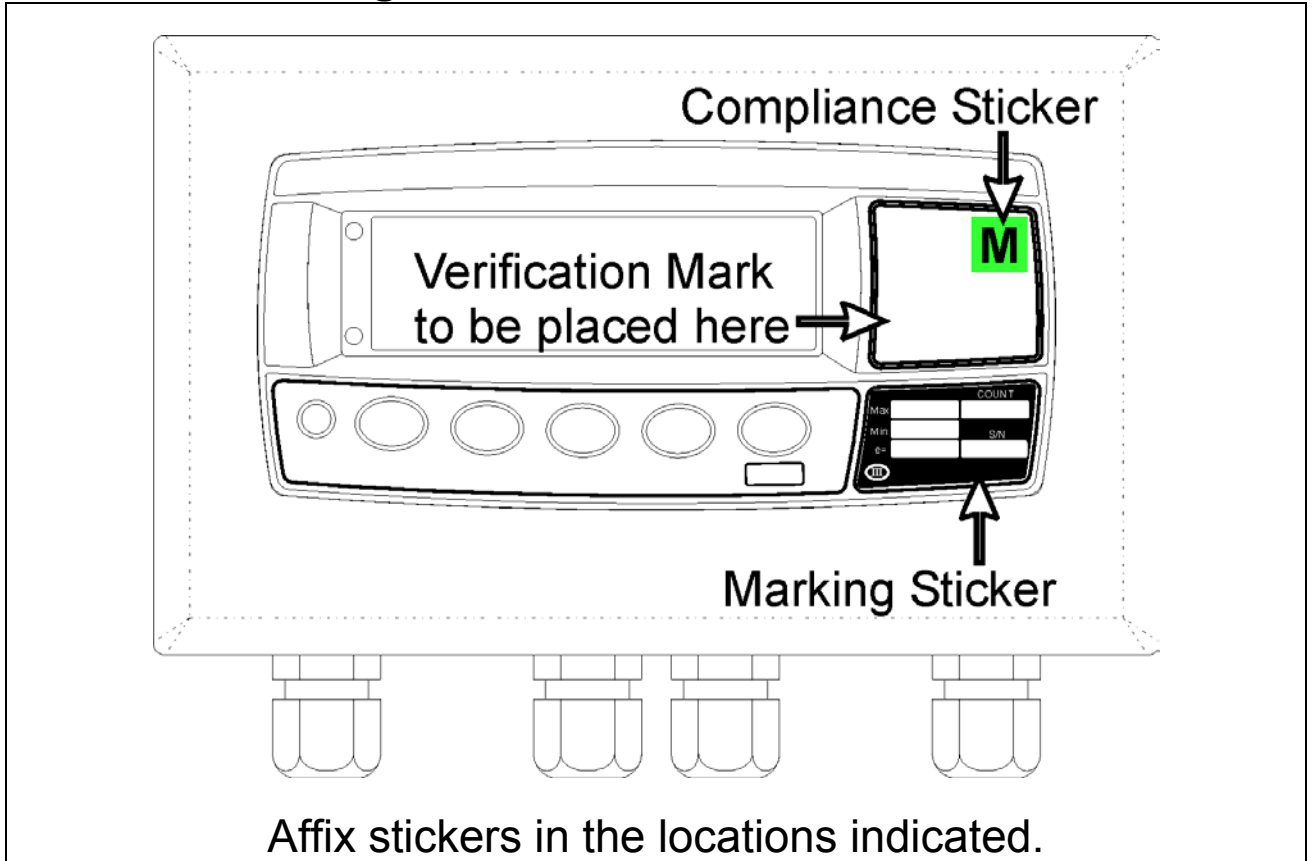

7. Instrument Setup

7.1. Calibration Counter

The **R300 Series** built-in calibration counter(s) monitor the number of times trade critical settings are altered. Refer to Trade Critical Settings below for more information and to the **OPTION:USE** setting page20.

The table below describes when the counter(s) will increment.

Industrial or OIML: The **Calibration Counter** increments when trade critical settings are changed. An example of the counter is **C.00019**.

NTEP: Two counters display.

The **Calibration Counter** increments when trade critical settings in the Calibration (**CAL**) menu are changed. An example of the counter is **C.00010**.

The **Configuration Counter** increments when other trade critical settings (ie. **not** in the **CAL** menu) are changed. An example of the counter is **F.00009**.

7.1.1. Trade Critical Settings

Trade critical settings can affect calibration and/or legal for trade performance. In this document the ⊗ symbol indicates the setting is trade critical. Each time a trade critical setting is altered, the calibration counter will be incremented by one.





7.2. rin-LINK

For information on setting up using the rin-LINK cable refer to rin-LINK page8.

7.3. Access Full Setup

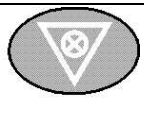
Full Setup provides access to configure and calibrate the instrument. All items in all menus will be enabled in Full Setup.

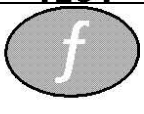
WARNING: Care should be taken to avoid inadvertently altering the Build or Calibration settings.

Ensure the instrument is on.	
R310 <ul style="list-style-type: none"> Press and hold the <POWER> and <TEST> keys together for two seconds. 	 +  TEST
R320 <ul style="list-style-type: none"> Press and hold the <POWER> and <FUNCTION> keys together for two seconds. 	 +  

7.4. Access Safe Setup

Safe Setup restricts access to the trade critical settings (marked with ⊗).

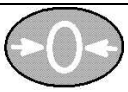
R300 Series: Ensure the instrument is on.	
<ul style="list-style-type: none"> Press and hold the <POWER> and <ZERO> keys together for two seconds. 	 +  ZERO

7.5. Exit Full or Safe Setup

To save settings, exit setup and return to the normal weighing mode use one of the following methods:







<ul style="list-style-type: none"> R310: Press <POWER> and <TEST> together for two seconds
<ul style="list-style-type: none"> R320: Press <POWER> and <FUNCTION> keys together for two seconds
<ul style="list-style-type: none"> R310 and R320: Press <POWER> and <ZERO> together for two seconds or select - End - from the menus.

Warning: If the power is interrupted while in setup (ie. by disconnecting the power cable or pressing the **<POWER>** key), unsaved settings will be lost.

7.6. Settings

The following tables identify the settings available for the **R300 Series**.







Rinstrum - R300 Series Digital Indicator Quick Start Manual Rev 1.5

GROUP (GRP)  ZERO	ITEM (ITM)  TARE	SELECT (SEL)  GROSS/NET	EDIT (EDT)  TEST OR PRINT	OK  TARE OR 
BUILD	DP⊗	Decimal Point Position	<u>000000</u> , <u>00000.0</u> , <u>00000.00</u> , <u>000.0000</u> , <u>00.00000</u> , <u>0.000000</u> Underline = Defaults	Accept
	CAP⊗	Maximum Capacity	000100 to 999999 Default = <u>003000</u> <SEL> changes position, <EDT> changes digit.	Accept
	RES⊗	Resolution (Count-By)	<u>1</u> , <u>2</u> , <u>5</u> , <u>10</u> , <u>20</u> , <u>50</u> , <u>100</u>	Accept
	UNITS⊗	Weighed Units	none, g, <u>kg</u> , lb, t	Accept
	HI.RES⊗	Resolution x 10 Mode	<u>OFF</u> , <u>ON</u>	Accept
	CABLE⊗	4-Wire or 6-Wire	<u>4</u> , <u>6</u>	Accept
OPTION	USE⊗	Scale Use	<u>INDUST</u> , <u>OIML</u> , <u>NTEP</u>	Accept
	FILTER	Reading Average (time in seconds)	none, <u>0.2</u> , <u>0.5</u> , <u>1.0</u> , <u>2.0</u> , <u>3.0</u> , <u>4.0</u>	Accept
	MOTION⊗	Motion Detection	<u>OFF</u> , <u>0.5-1.0</u> , <u>1.0-1.0</u> Default = 0.5 Graduations per Second	Accept
	INIT.Z	Initial Zero on Startup	<u>OFF</u> , <u>ON</u>	Accept
	Z.TRAC⊗	Zero Tracking Sensitivity	<u>OFF</u> , <u>SLOW</u> (0.5 grads/sec), <u>FAST</u> (10 grads/sec)	Accept
	Z.RANGE⊗	Zero Operating Range	<u>-2</u> <u>2</u> , <u>-1</u> <u>3</u> , <u>-20</u> <u>20</u> Default = -2_ 2 (-2% to +2%)	Accept
	Z.BAND⊗	Zero 'Dead' Band	<SEL> changes position, <EDT> changes digit. Default = <u>0</u>	Accept

Rinstrum - R300 Series Digital Indicator Quick Start Manual Rev 1.5

CAL	ZERO ⊗	Zero Calibration Routine Set between zero and full scale (Current weight displays)	<SEL> key to start. Current weight displays. Remove all weight. <SEL>, <EDT> or <OK> starts routine (Z.in P displays). <ITM> key to exit, <SEL>, <EDT> or <OK> to repeat routine.	
	SPAN ⊗	Span Calibration Routine Set between zero and full scale (Current weight displays)	<SEL> key to start. Current weight displays. Add test weight. <SEL> or <OK> to show calibration weight value. Set correct weight. <SEL> changes position, <EDT> changes digit. <ITM> or <OK> starts routine (S.in P displays). <ITM> key to exit, <SEL>, <EDT> or <OK> to re-edit calibration weight and repeat routine.	
ED.LIN ⊗ (R320 only)	Edit Linearisation Points Set between zero and full scale L1. --- Select Linearisation point 1 to 5 (L1, L2, L3, L4, L5). (Approx. % of full scale)	<SEL> to step through list of points. <OK> to change selected point or <ITM> to exit. After <OK> current weight displays. Add test weight. <OK> to enter corrected weight. <SEL> changes position, <EDT> changes digit. <OK> starts routine (L.in P displays). <ITM> key to exit, <OK> to repeat routine.		
CLR.LIN ⊗ (R320 only)	Clear Linearisation Points L1. --- Select Linearisation point 1 to 5 (L1, L2, L3, L4, L5)	<SEL> to step through list of points. <OK> to select point to clear or <ITM> to exit. After <OK> press <ITM> to choose Cont. Y (Yes) or Cont. N (No). <ITM> to return to CLR.LIN .		







Rinstrum - R300 Series Digital Indicator Quick Start Manual Rev 1.5

GROUP (GRP)  ZERO	ITEM (ITM)  TARE	SELECT (SEL)  GROSS/NET	EDIT (EDT)  TEST OR PRINT	OK  TARE OR  OK
CAL (ctd)	DIR.ZER ⊗ (R320 only)	Direct Zero Calibration (Current weight displays)	Underline = Defaults <OK> key to start. Current weight displays. <OK> to enter direct zero setting (in mV/V). <SEL> changes position, <EDT> changes digit. <OK> key to store new zero calibration. <ITM> to exit or <OK> to repeat operation.	
	DIR.SPN ⊗ (R320 only)	Direct Span Calibration (Current weight displays)	<OK> key to start. Current weight displays. <OK> to enter direct span setting (in mV/V). <SEL> changes position, <EDT> changes digit. <OK> key to store new span calibration. <ITM> to exit or <OK> to repeat operation.	
	FAC.CAL ⊗	Factory Calibration Cont. N (No) Cont. Y (Yes)	<u>Cont. N</u> Warning: Choosing Cont. Y will restore default factory calibration in BUILD and CAL menus.	Accept
SPEC	SAFE.PC	Safe Setup Passcode	(000000 no passcode). Set up to 6 digit passcode. <SEL> changes position, <EDT> changes digit. Activated only when FULL.PC is also set.	Accept
	FULL.PC	Full Setup Passcode	(000000 no passcode). Set up to 6 digit passcode. <SEL> changes position, <EDT> changes digit.	Accept

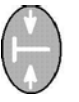
Rinstrum - R300 Series Digital Indicator Quick Start Manual Rev 1.5

SPEC (ctd)	KEY.LOC	Front Panel Key Locking P1234 (for R310) P12345 (for R320) (P for Power key. Other keys numbered from the left, ie. Zero=1.)	P1234 (for R310) and P12345 (for R320) Character indicates key is unlocked. (-) Dash indicates key is locked. <SEL> changes position, <EDT> changes digit.	Accept
	KEY.FN (R320 only)	<FUNCTION> Key Setting	NONE, TEST, COUNT, UNITS, HOLD, PEAK.H, LIVE.WT, SHOW.T	Accept
	AUT.OFF	Auto Power Off / Battery Operation	NEVER, 1, 5, 10 (time in minutes) Default = Never powers off automatically (Battery: powers down after 30 minutes)	Accept
	B.LIGHT	Backlight Operation	ON, OFF (Automatically turns indicator off after 10 seconds of inactivity)	Accept
	REM.FN (R320 only)	Remote Function	NONE, KEY1 to KEY5, BLANK (Activated only when SERIAL:TYPE is set to KEY)	Accept
SERIAL (R320 only)	TYPE	Serial Output Type	NET, AUTO.1, AUTO.2, PRINT, MASTER, KEY	Accept
	BAUD	Serial Baud Rate	2400, 4800, 9600	Accept
	BITS	Serial Format Options	N 8 1 - (Default Serial Format Options)	Accept
		Position 1: Parity Position 2: Data Bits Position 3: Stop Bits Position 4: DTR Handshake	<SEL> changes position, <EDT> changes digit. Parity: N None, O Odd, E Even Data Bits: 7 or 8 data bits Stop Bits: 1 or 2 stop bits DTR: (-) DTR disabled or d DTR enabled	

Rinstrum - R300 Series Digital Indicator Quick Start Manual Rev 1.5

GROUP (GRP)  ZERO	ITEM (ITM)  TARE	SELECT (SEL)  GROSS/NET	EDIT (EDT)  TEST OR PRINT	OK  TARE OR  f
SERIAL (ctd)	ADDRES	Instrument Address	01 to <u>31</u> <SEL> changes position, <EDT> changes digit.	Accept
	RST.CON 	Reset Printed Consecutive Numbers to 1 Cont. N (No) Cont. Y (Yes)	<u>Cont. N</u> <ITM> to choose Cont. Y (Yes) or Cont. N (No)	Accept
SET.PTS	SRC	Weight Source	<u>OFF, GROSS, DISP</u> (Displayed)	Accept
	TARG.HI	Target for Overweight Setpoint 1 (Output 1)	<u>-99999</u> to <u>999999</u> Default = <u>000000</u>	Accept
	TARG.LO	Target for Underweight Setpoint 2 (Output 2)	<u>-99999</u> to <u>999999</u> Default = <u>000000</u>	Accept
CLOC	FORMAT	Date Format Setting	<u>dd.mm.yy</u> or <u>mm.dd.yy</u>	Accept
(R320 only)	YEAR	Year Setting	<u>2000</u> to <u>2099</u> <SEL> changes position, <EDT> changes digit.	Accept
	MONTH	Month Setting	<u>01</u> to <u>12</u> <SEL> changes position, <EDT> changes digit.	Accept

Rinstrum - R300 Series Digital Indicator Quick Start Manual Rev 1.5

CLOC (ctd)	DAY	Day Setting	01 to 31 <SEL> changes position, <EDT> changes digit.	Accept
	HOUR	Hour Setting	00 to 23 <SEL> changes position, <EDT> changes digit.	Accept
	MINUTE	Minute Setting	00 to 59 <SEL> changes position, <EDT> changes digit.	Accept
TEST	SCALE	Scale Base Test Display	Display reads in milliVolts-per-Volt (factory calibrated to 0.1%) Verify the correct load cell capacity and/or load cell wiring is used. Remove weight from scale.	
	FRC.OUT (R320 only)	Force Outputs	<EDT> advances through outputs (ie. ON.1 and ON.2) <OK> turns outputs off and exits test. Default = OFF	
FACTRY	DEFLT	Restore Factory Defaults Cont. N (No) Cont. Y (Yes)	Cont. N Warning: Choosing Cont. Y will clear all stored data except BUILD and CAL menus.	Accept
- END -	EXIT SETUP	Save settings and return to normal weighing mode		Accept

8. Error Messages

8.1. Weighing Errors

- Check Setup = This item can be checked on site by service personnel

Error	Description	Resolution
(U - - - - -)	The weight is below the minimum allowable weight reading.	Increase the weight or decrease the minimum allowable weight reading.
(O - - - - -)	The weight is above the maximum allowable weight reading. Warning - overloading may damage mechanical scale elements.	Check the condition of load cell connections. Check for damaged load cell.
(ZERO) (ERROR)	The weight reading is beyond the limit set for Zero operation. The operation of the <ZERO> key is limited in the setup during installation. The indicator cannot be Zeroed at this weight.	Increase the Zero Range (Z.RANGE) or use the <TARE> key instead.
(STABLE) (ERROR)	Scale motion has prevented a <ZERO> , <TARE> or <PRINT> operation from occurring on command.	Try the operation again once the scale is stable.

8.2. Setup and Calibration Errors

Error	Description	Resolution
(ENTRY) (DENIED)	The instrument may be in Safe Setup and an item that needs Full Setup has been selected for editing.	Access Full Setup to edit the item.
	When accessing setup, more than three attempts have been made with the incorrect passcode.	Turn the instrument off. When the instrument is turned back on, enter the correct passcode to access setup.
(LIN.PT) (LO)	An attempt has been made to place a linearisation point below zero.	Incorrect linearisation point entered (must be between zero and full scale).
(PT.TOO) (CLOSE)	An attempt has been made to place a calibration point too close to an existing calibration point.	Re-enter the calibration point. Points must be spaced by at least 2% of full scale from each other.
(RES) (LO)	The scale build is configured for less than 100 graduations.	Check the resolution (count-by) and capacity settings.
(RES) (HIGH)	The scale build is configured for more than 30,000 graduations.	Check the resolution (count-by) and capacity settings.
(SPAN) (LO)	The load cell signal range (span) is too small for these settings.	Incorrect span weight entered (must be between zero and full scale). Scale wiring incorrect. Wrong load cell capacity (too large). Wrong or no calibration weight added to scale.
(SPAN) (HI)	The load cell signal range (span) is too large for these settings.	Incorrect span weight entered (must be between zero and full scale). Scale wiring incorrect. Load cell capacity too small for application.
(ZERO) (LO)	An attempt has been made to calibrate zero below -2mV/V.	Scale wiring incorrect.
(ZERO) (HI)	An attempt has been made to calibrate zero above +2mV/V.	Remove all weight from scale. Scale wiring incorrect.

8.3. Diagnostic Errors

- Check: This item can be checked on site by service personnel.
- Return for Service: The instrument must be returned to the manufacturer for factory service.

Error	Description	Resolution
(E0001)	The power supply voltage is too low.	Check supply
(E0002)	The power supply voltage is too high.	Check scale / cables
(E0010)	The temperature is outside of allowable limits.	Check location
(E0020)	Scale build is incorrect. The number of graduations has been set too low or too high.	Fix up scale build
(E0100)	The digital setup information has been lost.	Re-enter setup
(E0200)	The calibration information has been lost.	Re-calibrate
(E0300)	All setup information has been lost	Enter setup and calibrate
(E0400)	The factory information has been lost.	Return for Service
(E0800)	The EEPROM memory storage chip has failed	Return for Service
(E2000)	ADC Out of Range Error. This may be caused from a broken load cell cable.	Check BUILD:CABLE setting. Check load cell cable, wiring, etc.
(E4000)	The battery backed RAM data has lost data.	Re-enter setup
(E8000)	The FLASH program memory is incorrect	Return for Service

The **E** type error messages are additive. For example if instrument is running off batteries and the temperature drops, the battery voltage may be too low. The resulting error messages will be **E0011** (0001 + 0010). The numbers add in hexadecimal as follows:

1 - 2 - 3 - 4 - 5 - 6 - 7 - 8 - 9 - A - B - C - D - E - F

(For example, 2 + 4 = 6, or 4 + 8 = C)

Notes:

Notes:

Notes:

SMART WEIGHING SOLUTIONS

