

REV	DATE	DESCRIPTION	ECO	SIGN
1				

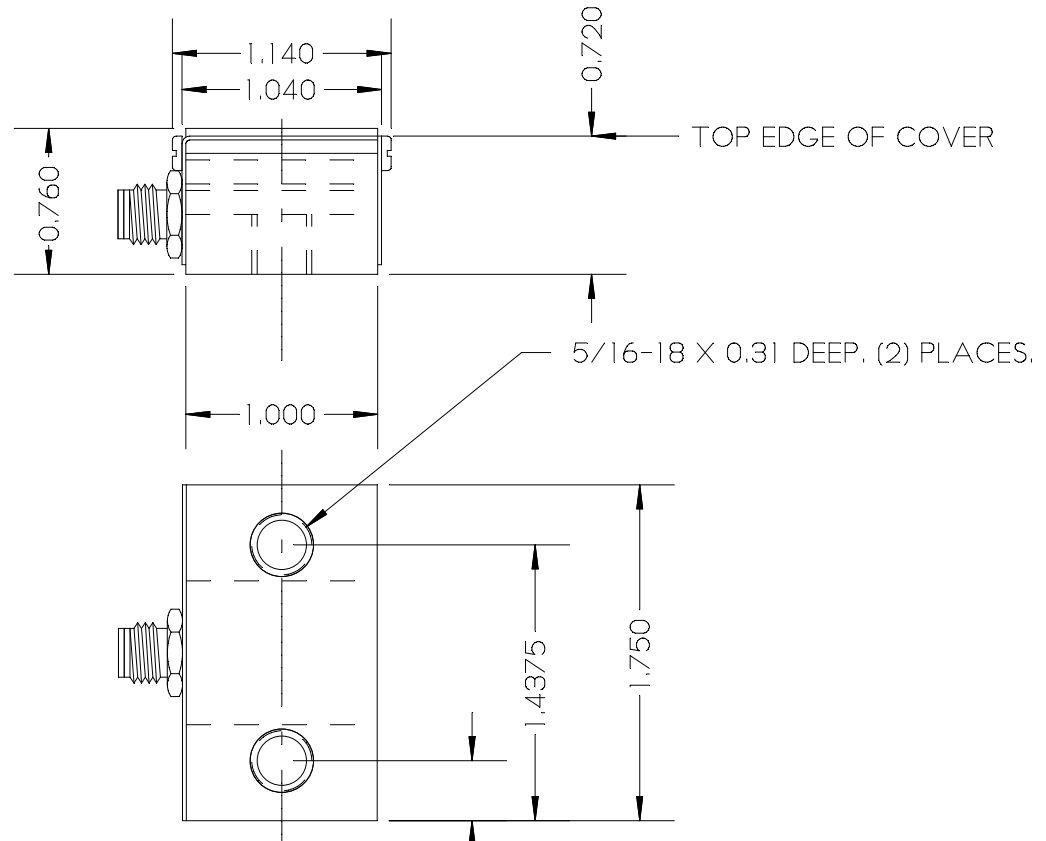
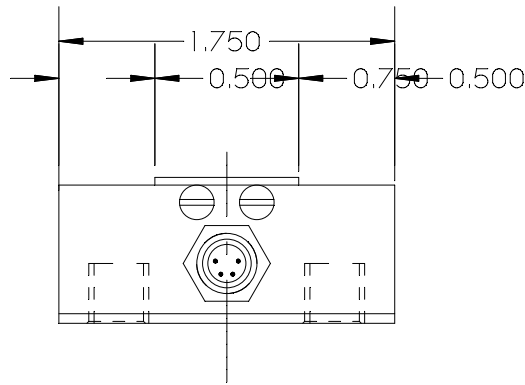

SPECIFICATIONS:

RATED CAPACITY	250 POUNDS
RATED OUTPUT,	2 mV/V typical
COMBINED ERROR	± 0.1 %
NON-REPEATABILITY	< 0.05 %
ZERO BALANCE	± 10 %
TEMPERATURE RANGE, COMPENSATED	+60 TO 160° F
TEMPERATURE EFFECT, OUTPUT	0.0005 % of Load / ° F
TEMPERATURE EFFECT, ZERO BALANCE	Not rated
BRIDGE IMPEDANCE	350 OHMS, typical
EXCITATION VOLTAGE (typical)	5 VDC or VAC rms
EXCITATION VOLTAGE, MAXIMUM	10 VDC or VAC rms
INSULATION RESISTANCE	5,000 MEG OHMS @ 50 VDC
MAXIMUM LOAD, SAFE	150 % F.S.
MAXIMUM LOAD, ULTIMATE	200 % F.S.
CONSTRUCTION	ALLOY STEEL

TURK (PKG 4M-2/S90/S818) OR EQUIVALENT



WIRE COLOR CODE:

+ EXCITATION	BROWN
- EXCITATION	BLACK
+ SIGNAL	WHITE
- SIGNAL	BLUE
SHIELD	GROUND

TURK or EQ.
(RECEPTACLE REAR SIDE)

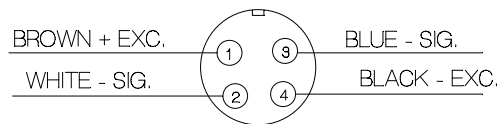

TOLERANCES UNLESS OTHERWISE SPECIFIED:
 .XXX = ± 0.005
 .XX = ± 0.015
 .X = ± 0.025
 SCALE: FULL
 FINISH: 32 MICRO IN. OR LESS ALL SURFACES
 MAT'L: TOOL STEEL
 HARDNESS: Rc 46-50



Designed By: Mettert
 Drawn By:
 Approved By:

Date: 4/26/04
 Date:
 Date:

Title / Description:
 SSI459 1,000 POUND
 RECTANGULAR L.C.
 SPECIFICATIONS

Dwg. Size: A
 Dwg. Type: SPEC

Part No. SSI459
 File Name 13839SP.FCD
 Doc. No. 13839