

REV	DATE	DESCRIPTION	ECO	SIGN
1	5/5/17	PILOT		BKM

SPECIFICATIONS:

RATED CAPACITY	20K POUNDS
RATED OUTPUT	2 mV/V typical
COMBINED ERROR	±0.5% / CURVE PROVIDED
NON-REPEATABILITY	0.02 %
ZERO BALANCE	± 10 %
TEMPERATURE RANGE, COMPENSATED	+60 TO 160° F
TEMPERATURE EFFECT, OUTPUT	0.0015 % of Load / ° F
TEMPERATURE EFFECT, ZERO BALANCE	0.0015 % of Load / ° F
INPUT IMPEDANCE, OUTPUT IMPEDANCE	350 OHMS, typical
EXCITATION VOLTAGE (typical)	10 VDC or VAC rms
EXCITATION VOLTAGE, MAXIMUM	15 VDC or VAC rms
INSULATION RESISTANCE	5,000 MEG OHMS @ 50 VDC
MAXIMUM LOAD, SAFE	150 % F.S.
MAXIMUM LOAD, ULTIMATE	200 % F.S.
DEFLECTION AT RATED CAPACITY, APPROXIMATE	0.007 in.
CONSTRUCTION	TOOL STEEL
RECEPTACLE ON LOAD CELL	TURCK MFSS 4-0.2

WIRE COLOR CODE:	TURCK	PIN NO.
+EXCITATION	BROWN	1
+SIGNAL	WHITE	2
- SIG	BLUE	3
- EXCITATION	BLACK	4

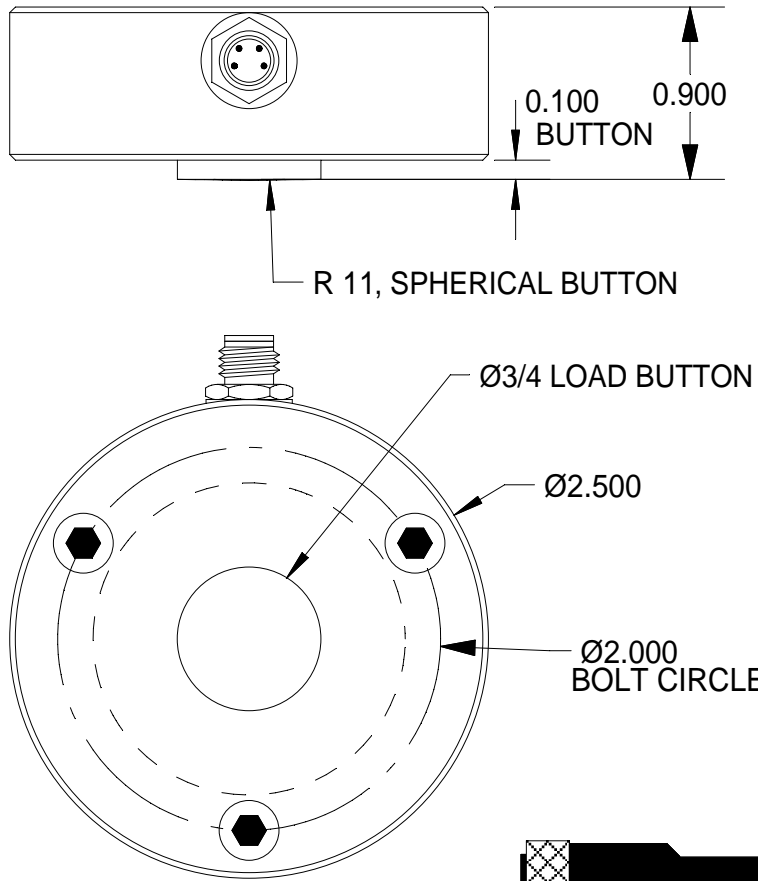

R 11, SPHERICAL BUTTON

Ø3/4 LOAD BUTTON

Ø2.500

Ø2.000
BOLT CIRCLE FOR #10 S.H.C.S.



T.T.I. NO. (4247-222) TURCK PKG4M-4-S90/S618

FEMALE PLUG

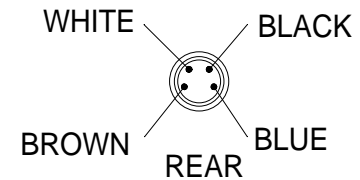

TOLERANCES UNLESS OTHERWISE SPECIFIED:

.XXX = ± 0.005

.XX = ± 0.015

.X = ± 0.025

SCALE: FULL



TOLEDO
TRANSDUCERS,
INC.

Designed By: **Mettert**

Date: **1/9/98**

Drawn By:

Date:

Approved By:

Date:

Title / Description:

20K LBS LOAD CELL 2 mV/V

SS1175M20K SPECIFICATIONS

Dwg. Size:

A

Dwg. Type:

SPEC

Page 1 of 1

Part No.

SS1175M20K

File Name

Doc. No.