

REV	DATE	DESCRIPTION	ECO	SIGN
1	01/29/97	RELEASE TO PILOT	462	RAB

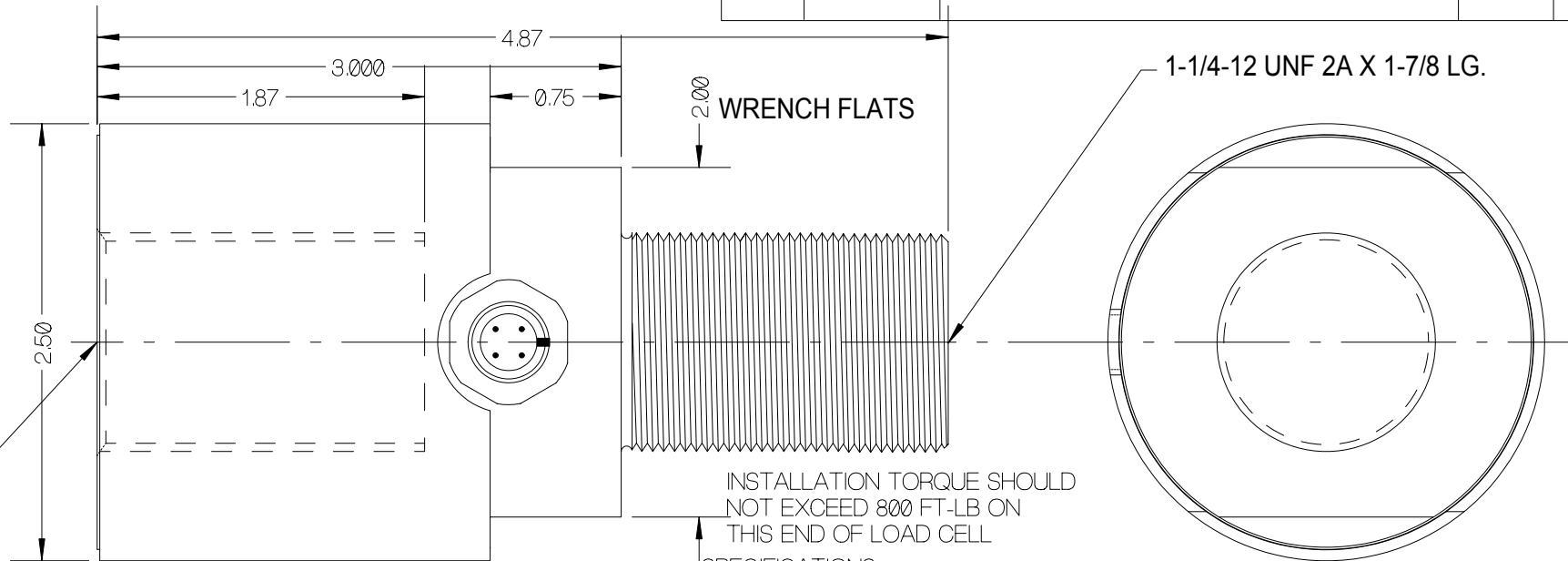

1-1/4-12 UNF 2B X 1-7/8 LG.
 TOOL TORQUE SHOULD NOT EXCEED 800 FT-LB ON THIS END OF LOAD CELL

INSTALLATION TORQUE SHOULD NOT EXCEED 800 FT-LB ON THIS END OF LOAD CELL

SPECIFICATIONS:

RATED CAPACITY	60,000 POUNDS
RATED OUTPUT	2 mV/V typical
COMBINED ERROR	0.25 %
NON-REPEATABILITY	0.05 %
ZERO BALANCE	± 1 %
TEMPERATURE RANGE, COMPENSATED	+14 TO 104° F
TEMPERATURE EFFECT, OUTPUT	0.014 % / ° F
TEMPERATURE EFFECT, ZERO BALANCE	0.05 % / ° F
INPUT / OUTPUT IMPEDANCE	700 OHMS, typical
EXCITATION VOLTAGE (typical)	10 VDC or VAC rms
EXCITATION VOLTAGE, MAXIMUM	15 VDC or VAC rms
INSULATION RESISTANCE	5,000 MEG OHMS @ 50 VDC
MAXIMUM LOAD, SAFE	150 % F.S.
MAXIMUM LOAD, ULTIMATE	300 % F.S.

6.56 FEET, 3M OF SENSOR CABLE.

STRAIGHT FEMALE PLUG NO.80456-A
 (OPTIONAL FEMALE 90 PLUG NO.80496-A)

(RECEPTACLE FRONT SIDE)

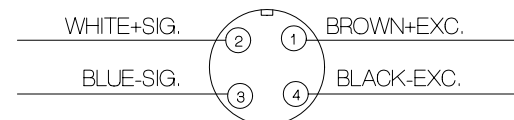

TURCK

TOLERANCES UNLESS OTHERWISE SPECIFIED:

.XXX = ± 0.005

.XX = ± 0.015

.X = ± 0.025

SCALE: FULL

FINISH: FINE BRUSHED FINISH, O.D. NO MARKS

MATL: ALLOY STEEL / STAINLESS STEEL



TOLEDO
 TRANSDUCERS,
 INC.

Designed By: Mettert

Date: 1/17/97

Title / Description:
 ROD END LOAD CELL
 SPECIFICATIONS

Part No. SS1122-60K

Drawn By:

Date:

File Name 10302SP.FCD

Approved By:

Date:

Dwg. Size: A
 Dwg. Type: SPEC

Page 1 of 1

Doc. No. 10302