

REV	DATE	DESCRIPTION	ECO	SIGN
A	8/8/01	RELEASE TO PRODUCTION	1064	RAB

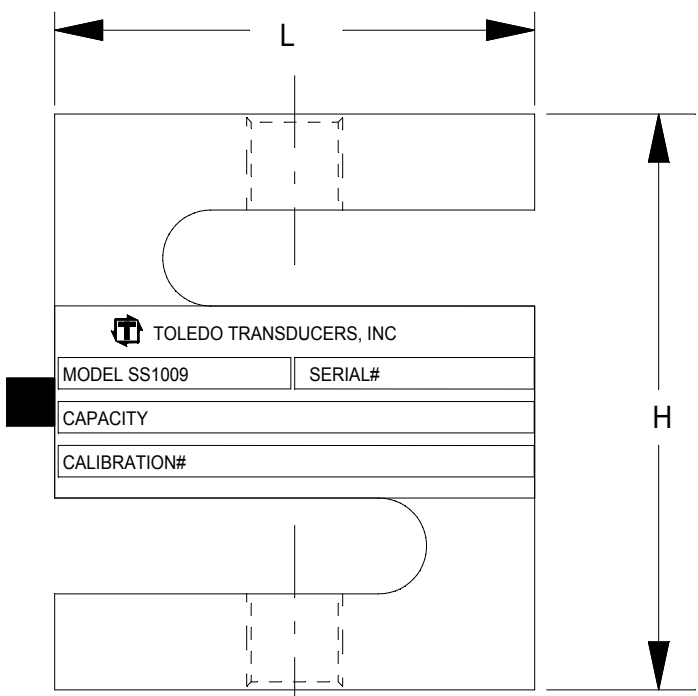
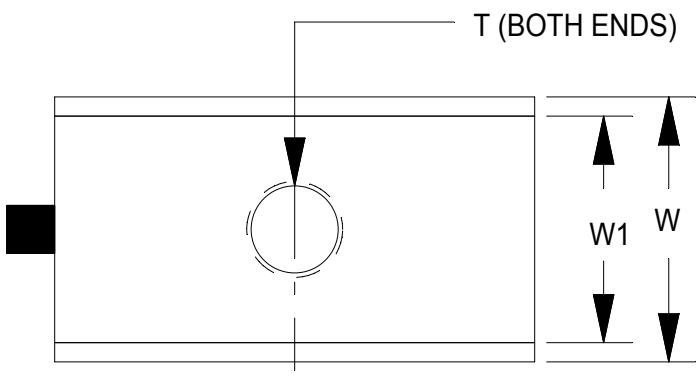

Rated Capacity	AS NOTED LBS
Rate Output, typical	3 mV/V
Rate Output, typical**	2 mV/V**
Combined Error	<0.02 %*
Non-repeatability	0.01 %
Creep, 30 minutes	0.05 %
Zero Balance	± 10 %
Temperature Range, Compensated	+ 14 to + 104° F
Temperature Effect, Output	0.05 % of load / 100° F
Temperature Effect, Zero Balance	0.15% / 100° F
Input Impedance	410 Ohms ± 20 %
Output Impedance	350 Ohms ± 1 %
Insulation Resistance	5000 Megohms at 50 VDC
Maximum Load, Safe	150 %
Maximum Load, Ultimate	200 %

RATED CAPACITY	"T" IN	"L" IN	"W" IN	"W1" IN	"H" IN
25**	1/4-28 UNF	2.00	0.75	0.50	2.50
50**	1/4-28 UNF	2.00	0.75	0.50	2.50
100**	1/4-28 UNF	2.00	0.75	0.50	2.50
150**	1/4-28 UNF	2.00	0.75	0.50	2.50
200**	1/4-28 UNF	2.00	0.75	0.50	2.50
250	3/8-24 UNF	2.00	0.75	0.50	3.00
500-1,500	1/2-20 UNF	2.00	1.00	0.75	3.00
2,000-3,000	1/2-20 UNF	2.00	1.25	1.00	3.00
5,000	3/4-16 UNF	3.00	1.25	1.00	4.25
10,000	3/4-16 UNF	3.00	1.25	1.00	4.75
15,000	1-14 UNS	3.95	1.50	1.25	5.50
20,000	1-1/4-12 UNF	4.94	2.19	1.94	7.00
40,000	1-1/2-12 UNF	6.00	2.75	2.50	10.00

**TOLEDO TRANSDUCERS, INC.**

MODEL SS1009	SERIAL#
CAPACITY	
CALIBRATION#	

20 FOOT LONG CABLE  
SHIELD/DRAIN  
RED + EXC.  
WHITE - SIG.  
GREEN + SIG.  
BLACK - EXC.

\* Combined effects of Non-linearity and Hysteresis: The maximum deviation from the straight line, drawn between the original no-load and Rated capacity, expressed as a percent of Rated Output and measured on increasing and decreasing load.

<p>TOLEDO TRANSDUCERS, INC.</p>	Designed By:	Mettert	Date:	3/15/93	Title / Description:		Part No.	
	Drawn By:		Date:		"S" BEAM LOAD CELL		File Name	
	Approved By:		Date:		Dwg. Size:	Dwg. Type:	Doc. No.	
				A	FAB	Page 1 of 1	11777	