

(REAR RECEPTACLE SIDE)

GREEN + EXC.

WHITE + SIG.

BLACK - EXC.

BLUE/RED - SIG.

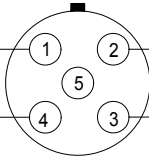

REV	DATE	DESCRIPTION	ECO	SIGN
1	5/25/00	RELEASE TO PILOT	920	RAB



TURCK RK 4.5T-4/S618, ORDER NO. (4245-222)

1.50 HEX.
ACROSS THE FLATS
MAX. TORQUE HERE
600 Ft. Lbs

1-14 2A THREAD.

1-14 2B TAP X 1.75 of
FULL THREAD.
MAX. TORQUE HERE
500 Ft. Lbs

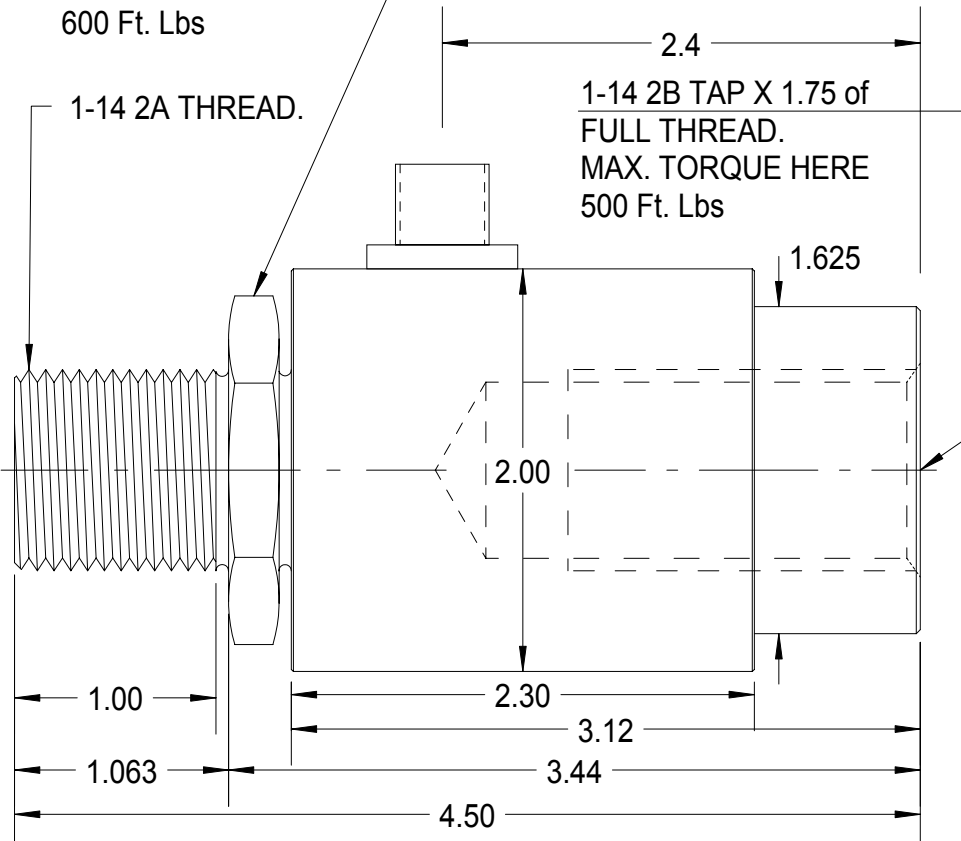

SPECIFICATIONS:

Rated Capacity	10,000 pounds
Rated Output, typical	1.8 mV/V
Combined error	0.25 % F.S.
Non-repeatability	0.05 % F.S.
Zero Balance	1 % R.O.
Temperature Range, Compensated	50 F to 120 F
Temperature Effect, Output	0.005 % of load / F
Temperature Effects, Zero Balance	0.005 % / R.O. / F
Bridge Impedance, Typical	350 ohms
Excitation Voltage, Typical	10 VDC or VAC rms
Excitation Voltage, Maximum	15 VDC or VAC rms
Insulation Resistance	> 5,000 megohms at 50 VDC
Overload, Safe	150 % over capacity
Overload, Ultimate	200 % over capacity
Construction	Alloy Steel
Cover	Stainless Steel

WIRE COLOR CODE:		T.T.I. STD.	PIN NO.
+EXCITATION	BROWN	GREEN	1
+SIGNAL	WHITE	WHITE	2
- SIG	BLUE	RED	3
- EXCITATION	BLACK	BLACK	4
OPEN			5

TOLERANCES UNLESS OTHERWISE SPECIFIED:
 .XXX = ± 0.005
 .XX = ± 0.015
 .X = ± 0.025
 FINISH: 32 MICRO INCH OR LESS
 MAT'L: ALLOY STEEL
 HARDNESS: Rc 40-46

SCALE: FULL



Designed By: **Mettert**

Date: **4/26/00**

Title / Description:
**SS1326-10KLB
SPECIFICATIONS**

Part No. **SS1326-10K**

Drawn By:

Date:

File Name **11581SP.FCD**

Approved By:

Date:

Dwg. Size: **A**
Dwg. Type: **SPEC**

Doc. No. **11581**